

Installing Stools onto Stool Table Legs

WARNING

Use caution when operating table without stools installed. Table lift is assisted via an internal torsion lift system. The table may be hard to operate until the stools are installed. IE the table will be harder to push open from the folded position. The table may close quickly from the 2/3d's cleaning position to the folded stored position.

STEP #1 - Unpack and Inspect: (See Figure #1)

Inspect the stools for any shipping damage to the top or the support ribs underneath. Make sure the hardware is with the stools.

STEP #2 - Install Stool to Leg Upright:

- Install the middle stools first while the table is folded.

(See Figures #1, 2, 3)

- 1) Slide stool onto the upright. Use a spinning motion while pressing down if necessary until the holes in the stool line up with the leg upright. Sometimes some grease may be needed if the stool is tight when installing.
- 2) Slide one flange nut onto bolt and insert into hole from the outside of the table. (You want the bolt heads to be facing out when the table is folded).
- 3) Check that the flange nut is concentric with the curve of the stool stem.
- 4) Once bolt is through the other side install the second flange nut concentric to the stool stem.
- 5) Hand tighten the lock nut to the bolt.
- 6) Tighten the bolt/nut until the washers are close to the stool stem.
- 7) !!CRITICAL STEP!! Be sure the washers are lined up in the molded groove in the stool stem before tightening completely.**
- 8) Once both washers are lined up with the groove in stem, proceed to tighten the bolt/nut until the stool no longer rotates or wiggles. It is OK to tighten down very hard. **(See Figure #3)**

- Some tables require the table to be opened to the 2/3rd's position in order to slide stool on. Fold table back to the locked storage position to install hardware. Repeat steps (1-8) above.

STEP #3 - Inspect All Stools and Test Table:

- 1) Check that all stools hardware are installed properly.
- 2) Be sure the bolt/nut are installed tight so the stools do not move.
- 3) Open/close the table to be sure it operated properly.

(Please contact customer service with any installation questions)

Hardware included for each stool: Tools Required:

- | | | |
|---------------------------|--------------------|--------------------------------|
| (1) Hex bolt; | (2) Fender washers | (1) 13mm (or 1/2") Ratchet. |
| (1) Nylon insert lock nut | | (1) 13mm (or 1/2") box wrench. |

Time Required to Install: 1min/stool. Time may be longer at first due to learning curve until assembly process better understood.

Figure #1: Stool Assembly Explosion

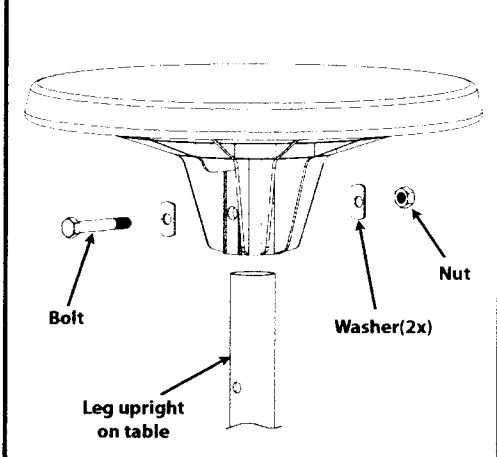

Figure #2: (MTFB12 Folded Shown)

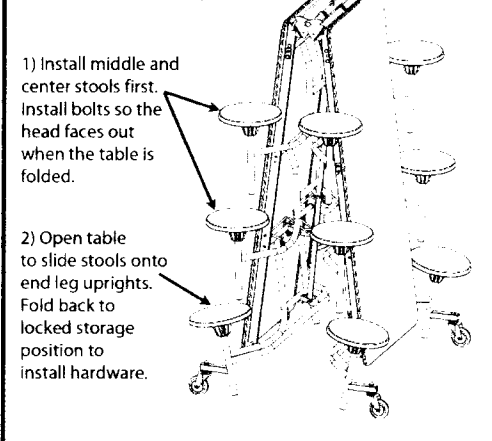

Figure #3: CRITICAL ASSEMBLY DETAIL

